

## Manual for Q3215UG2-P Nano Motherboard v1.0

### Catalogue

I、	Product Description . . . . .	2
1.	Brief Introduction . . . . .	2
2.	Version Specification. . . . .	2
3.	Characteristics & Performances. . . . .	2
II、	Product Overview . . . . .	3
1.	Front View . . . . .	3
2.	Back View . . . . .	4
3.	Connectors and Headers . . . . .	4
III、	Detailed Description of Connection Ports. . . . .	5
1.	Power Input Port . . . . .	5
2.	HDMI Connector . . . . .	6
3.	1000M LAN Port . . . . .	6
4.	USB 3.0 Port . . . . .	6
5.	Microphone Input . . . . .	6
6.	Audi Output Port . . . . .	6
7.	2 * USB 2.0 Ports . . . . .	6
8.	Serial port headers (COM1). . . . .	6
9.	Serial port headers (COM2). . . . .	7
10.	Serial port headers (COM3). . . . .	7
11.	Serial port headers (COM4). . . . .	7
12.	Serial port headers (COM5). . . . .	7
13.	Serial port headers (COM6). . . . .	7
14.	HDD led. . . . .	7
15.	Power led. . . . .	7
16.	Power Switch. . . . .	7
17.	SATA Power Connector . . . . .	7
18.	SATA 3.0 Port . . . . .	8
19.	SATA Power Connector . . . . .	8
20.	SATA 3.0 Port . . . . .	8
21.	About BIOS . . . . .	8
22.	GPIO . . . . .	8
23.	Extended Pin for External Panel . . . . .	9
24.	Automatically boot jumper . . . . .	9
25.	Extended Audio Input and Output Pin. . . . .	9

26.	Extended USB Pin . . . . .	10
27.	RS232/RS485 Function switch jumper (J1C2) . . . . .	10
28.	RS232/RS485 Function switch jumper (J2C2) . . . . .	10
29.	System Fan Header . . . . .	11
30.	CPU Fan Header . . . . .	11
31.	DC in header . . . . .	11
32.	VGA Connection Pin. . . . .	11
33.	Intel Haswell/Broadwell Processor . . . . .	12
34.	PCI Express Full-Mini Card Slot (For MSATA SSD) . . . . .	12
35.	PCI Express Half-Mini Card Slot . . . . .	12
36.	M.2 SSD slot . . . . .	12
37.	SIM card slot . . . . .	12
38.	Memory Slot . . . . .	12
39.	Battery Slot . . . . .	12

## I、Product Description

### 1. Brief Introduction

Q3215UG2-P is a 3.5 inch Mini-ITX motherboard designed based on the Intel Haswell/Broadwell Platform, with the size of 148mm x104mm.

### 2. Version Specification

Version NO.	Motherboard NO.	QTY of Network Card	QTY of USB Ports
<b>V1.0</b>	Q3XX	<b>2</b>	<b>6</b>

### 3. Characteristics & Performances

#### 1) Great reliability

With the adoption of the Haswell/Broadwell ultra-low power consumption processor and switching mode power supply, Q3215UG2-P motherboard can provide stable, sufficient and efficient power. The stability of the motherboard is further guaranteed with the switching mode of power supply applied in memory, too. All of the external devices of the motherboard is composed of some anti-static and jam-proof components which ensured the operation of a stable and efficient system.

#### 2) High Performance

It considerably increases performance of the platform by employing the Haswell/Broadwell chipset of Intel and SATA3.0

#### 3) Full Support of BIOS

Support Diskless booting and Wake on LAN

**4) Working Condition**

Working Temperature : -10°C ~ 50°C

Working Humidity : 5% ~ 95% ( Non-gel )

**II、 Product Overview**

**1. Front View**

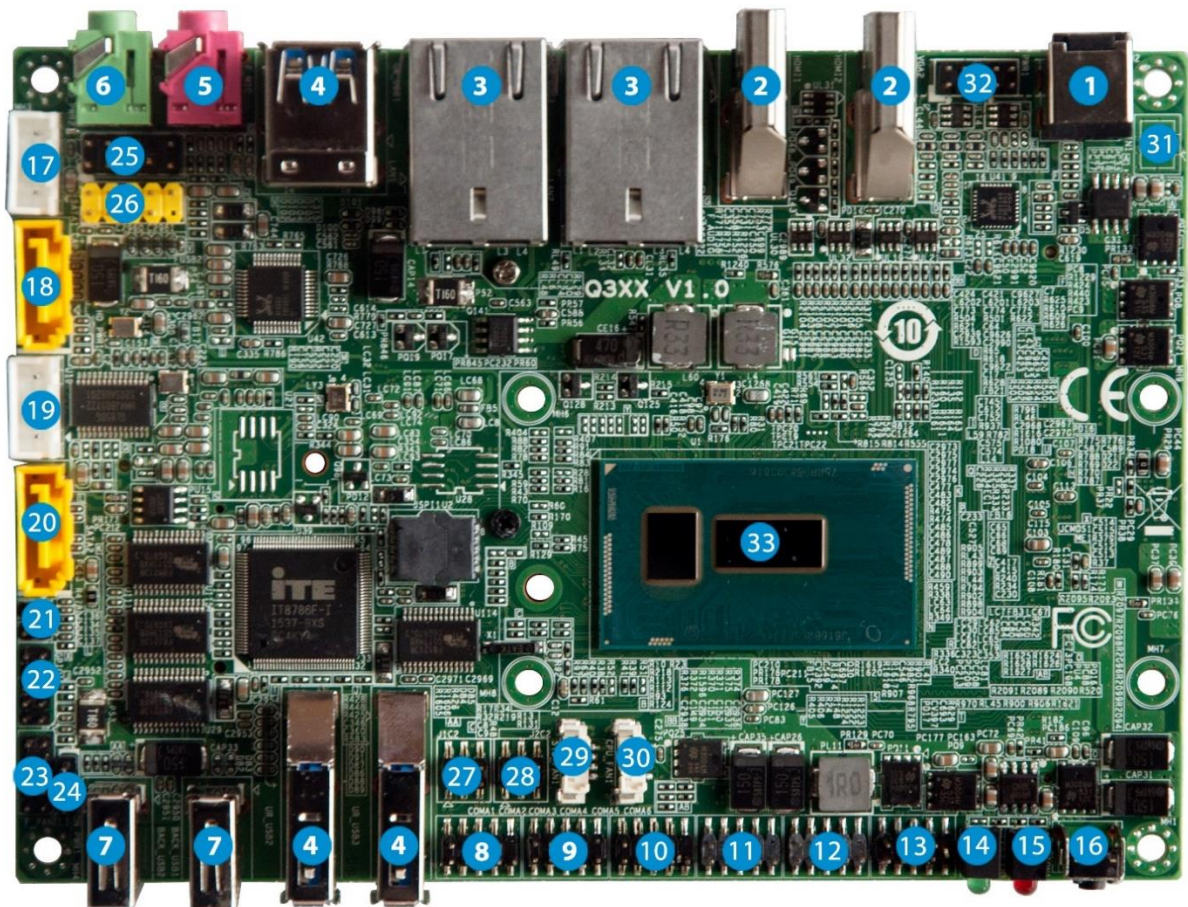

**2. Back View**

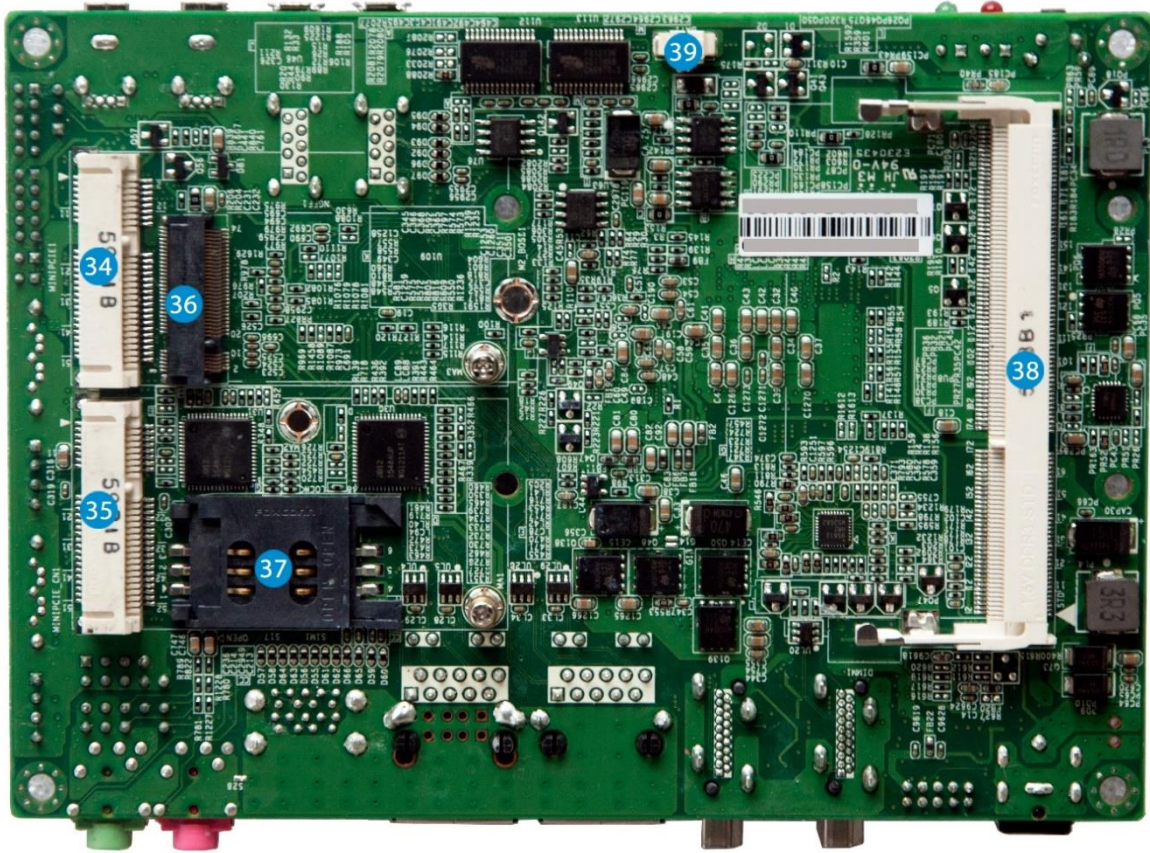

**3. Connectors and Headers**

Pin#	Description	Signal Name
1	12V DC in connector	PWR1
2	HDMI connector	HDMI1,HDMI2
3	Lan connector	LAN1,LAN2
4	4 * USB 3.0 ports	UR_USB1,UR_USB2,UR_USB3
5	MIC: Connect to outside Microphone	F_MIC
6	(Line out): Connect to outside audio device	F_OUT
7	2 * USB 2.0 ports	BACK_USB1,BACK_USB2
8	Serial port expansion header (COM1)	COMA1
9	Serial port expansion header (COM2) (RS485 optional)	COMA2
10	Serial port expansion header (COM3)	COMA3
11	Serial port expansion header (COM4)	COMA4
12	Serial port expansion header (COM5)	COMA5

13	Serial port expansion header (COM6)	COMA6
14	HDD led	LED2
15	Power led	LED1
16	Power button	BUTTON1
17	SATA1 power connector	HD_PWR2
18	SATA1 port	SATA1
19*	SATA2 power connector (optional, only for Core Processor)	HD_PWR1
20*	SATA2 port (optional)	SATA2
21	CMOS clean header	/
22	GPIO header	GPIO1
23	Front panel header	F_PANEL1
24	Automatically boot jumper	ON_PWR1
25	Front panel audio header	/
26	Front panel USB 2.0 header	FUSB2
27	RS232/RS485 Function switch jumper	J1C2
28	RS232/RS485 Function switch jumper	J2C2
29	System fan header	SYS_FAN1
30	CPU fan header	CPU_FAN1
31	DC in header (optional)	PWR_IN1
32	VGA extension header	VGA2
33	Processor (Support HASWELL and BROADWELL )	U1
34	Mini PCI Express connector for MSATA SSD	MINIPCIE1
35	Mini PCI Express connector for WIFI,Bluetooth,3G module	MINIPCIE_CN1
36*	M.2 SSD Socket (optional)	NGFF1
37	SIM card socket	SIM1
38	DDR3L SO-DIMM socket	DIMM1
39	Battery connector	BAT1

\* Only for Core Processor

### III、 Detailed Description of Connection Ports

#### 1. Power Input Port

Increased reliability with intensive electrical socket outlet.

12V power supply input. Suitable for power adapter (Internal: the positive pole, external: the negative pole) which has the outside diameter of 5.5mm and inside diameter of 2.5mm.

**2. HDMI Connector**

Standard HDMI port

**3. 1000M LAN Port**

Intel I211 gigabit network, support diskless booting and Wake on LAN. ( Dual gigabit network )

**4. USB 3.0 Port**

USB3.0 port (5.0Gbps, 640MB/s )

**5. Microphone Input**

Universal microphone input port

**6. Audi Output Port**

Universal audio output port

**7. 2 \* USB 2.0 Ports**

Universal USB2.0 port.

**8. Serial port headers (COM1)**

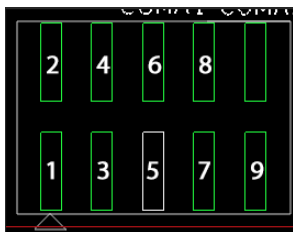

Pin#	Signal	Define	Note
1	DCD	Data Carrier Detect	
2	RXD	Received Data	
3	TXD	Transmitted Data	
4	DTR	Data Terminal Ready	
5	GND	Signal Ground	
6	DSR	Data Send Ready	
7	RTS	Request to Send	
8	CTS	Clear to Send	
9	RI	Ring Indicator	

**9. Serial port headers (COM2)**

COM2, PIN definition refer to NO.8.

A. RS232 Function

When item No. 27 & No. 28 choose to RS232, COM2 interface definition please refer to Item No. 8.

B. RS485 Function

When item No. 27 & No. 28 choose to RS2485, COM2 interface definition as below:

Pin#	Signal
1	RS485-
2	RS485+
3-9	n/c

**10. Serial port headers (COM3)**

COM3, PIN definition refer to NO.8.

**11. Serial port headers (COM4)**

COM4, PIN definition refer to NO.8.

**12. Serial port headers (COM5)**

COM5, PIN definition refer to NO.8.

**13. Serial port headers (COM6)**

COM6, PIN definition refer to NO.8.

**14. HDD led**

Red color.

**15. Power led**

Green color.

**16. Power Switch**

Power switch button

**17. SATA Power Connector**

Special power interface, please ask for matching wire from the distributor.

When Power adaptor is 12V, 3.5" HDD can be supported.

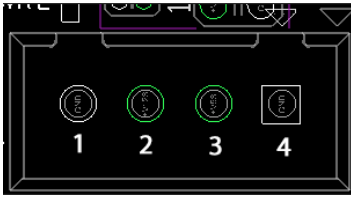

Pin#	1	2	3	4
Signal	Ground	+12V	+5V	GND

Pin spacing : 2.54mm

PS : Standard SATA Power Connector Definition

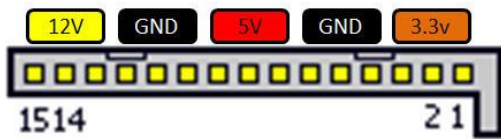

**18. SATA 3.0 Port**

Universal SATA3.0 port

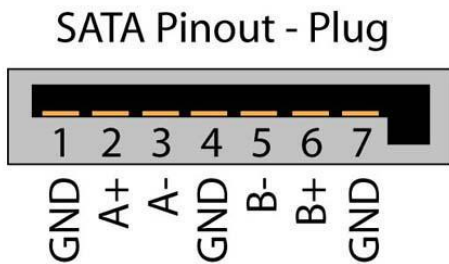

**19. SATA Power Connector**

PIN definition refer to NO.17, Only for Intel Core series

**20. SATA 3.0 Port**

PIN definition refer to NO.18. Only for Intel Core series

**21. About BIOS**

N/c

**22. GPIO**



Pin spacing : 2.0mm Uncompleted



### 23. Extended Pin for External Panel

For accessing the power switch, power LED, HDD LED, reset switch.

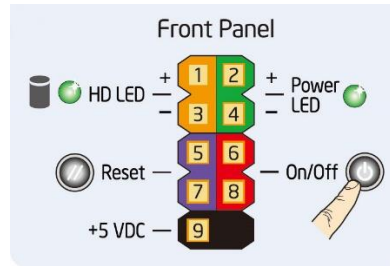

Pin spacing : 2.0mm

### 24. Automatically boot jumper



Functions	PIN#
<b>Enable</b>	2-3
<b>Disable</b>	1-2

Pin spacing : 2.54mm

### 25. Extended Audio Input and Output Pin

For accessing extended audio input and output pin

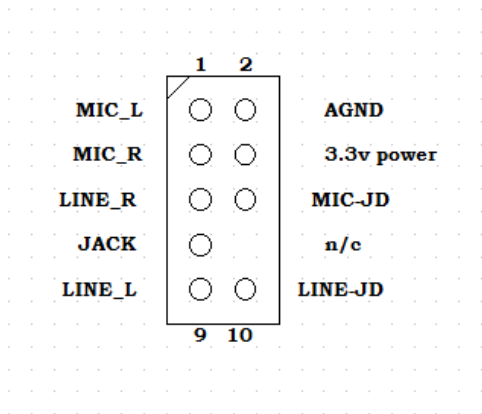

Pin spacing : 2.54mm

**26. Extended USB Pin**

Pin for accessing extended USB2.0.

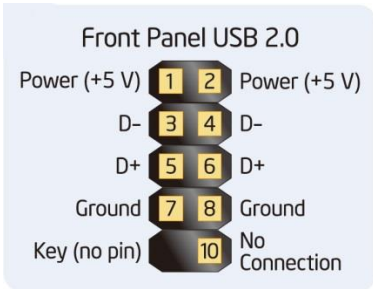

Pin#	Signal	Pin#	Signal
1	+5V DC	2	+5V DC
3	D-	4	D-
5	D+	6	D+
7	Ground	8	Ground
9	KEY (no pin)	10	No Connect

Pin spacing : 2.54mm

**27. RS232/RS485 Function switch jumper (J1C2)**

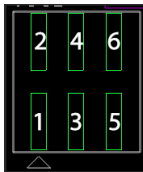

Function select	Connecting pins
<b>RS232</b>	1-3,2-4
<b>RS485</b>	3-5, 4-6

Pin spacing : 2.0mm

**28. RS232/RS485 Function switch jumper (J2C2)**

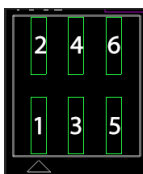

Function select	Connecting pins
<b>RS232</b>	1-2
<b>RS485</b>	3-4, 5-6

Pin spacing : 2.0mm

### 29. System Fan Header

For connecting fan of the system

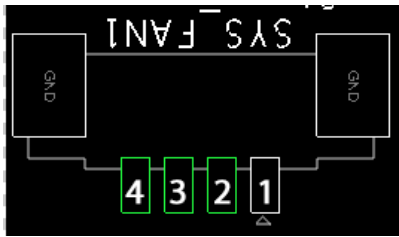

Pin#	Signal
1	GND
2	+5V
3	Detection
4	Control

### 30. CPU Fan Header

For connecting fan of the CPU.



Pin#	Signal
1	GND
2	+5V
3	Detection
4	Control

### 31. DC in header

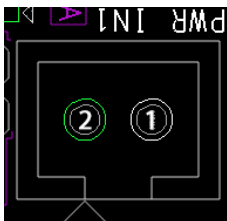

Pin#	Signal
1	GND
2	+12V

### 32. VGA Connection Pin

Pin for accessing extended VGA port, standard VGA Signal output

Pin spacing : 2.0mm

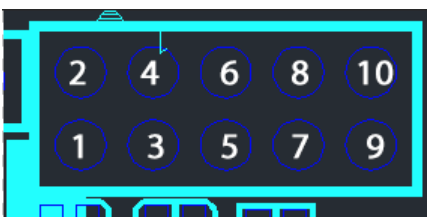

Pin#	Signal	Pin#	Signal
1	VCC_PWR	2	RED
3	DDC_DATA	4	GREEN
5	DDC_CLK	6	BLUE
7	VSYNC	8	GND
9	HSYNC	10	GND

**33. Intel Haswell/Broadwell Processor**

Support Haswell / Broadwell FCBGA1168 processor

**34. PCI Express Full-Mini Card Slot (For MSATA SSD)**

Universal MINI SATA port for accessing MSATA SSD

**35. PCI Express Half-Mini Card Slot**

- a. Half Mini PCIE port for extending WIFI and Bluetooth
- b. Full Mini PCIE port for extending 3G/4G module.

**36. M.2 SSD slot**

Due to the structure, it cannot be used with Item No. 34 at the same time.

Only for Intel Core Processor.

**37. SIM card slot**

Coordinate with Item No. 35, the function of 3G/4G can be supported.

**38. Memory Slot**

Only suitable for SO-DIMM of 1333 MHz or 1600 MHz (1.35V) working frequency, maximum 8 GB single-sided module.

**39. Battery Slot**

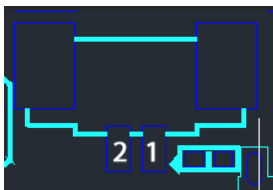

Pin#	Signal
1	+
2	-